

MODEL NAME
TRACK_SUPPORT

TITLE

1

2

3

4

D

D

C

C

B

B

A

A

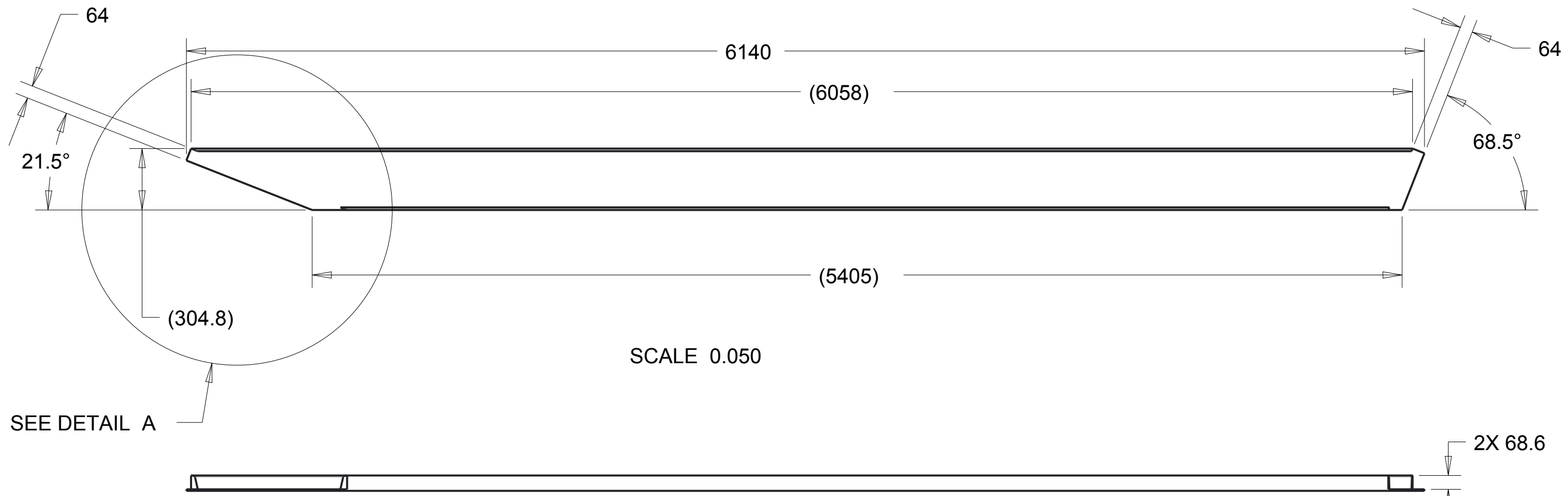

SCALE 0.050

SEE DETAIL A

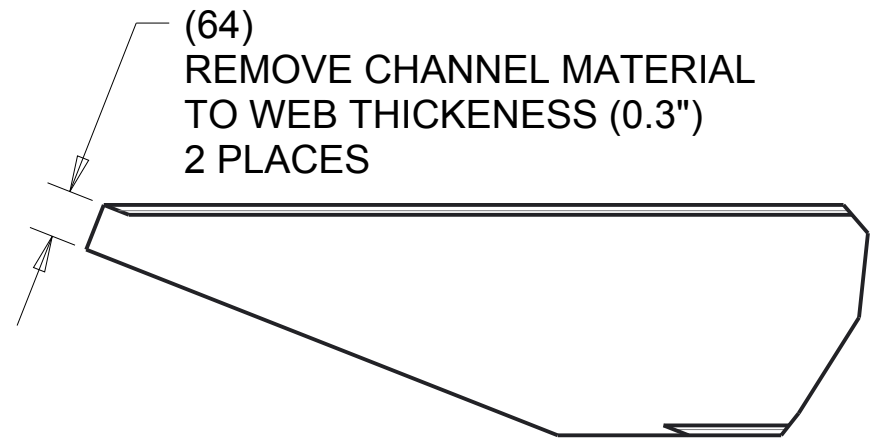

DETAIL A
SCALE 0.100

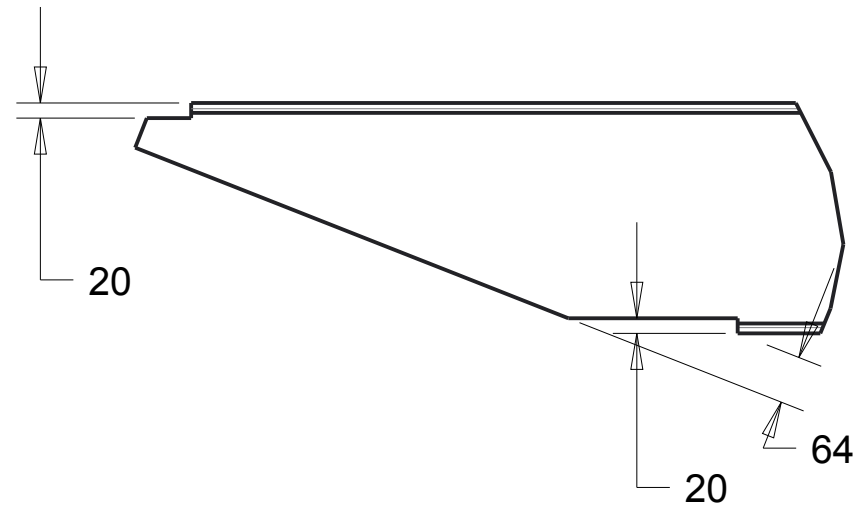

DETAIL A-ALT
SCALE 0.100
ALTERNATE MANUFACTURING METHOD
REMOVE MATERIAL AS SHOWN

NOTES:

1. MATERIAL: ALUMINIUM 6061
2. MATERIAL STOCK: AS CHANNEL 12" X 3" X 0.3"
3. BREAK ALL SHARP EDGES

		DRAWN BY	DATE
		CHECKED BY	DATE
		APPROVED BY	DATE
THIS DOCUMENT IS SUPPLIED IN CONFIDENCE. NO REPRODUCTION OF THIS DOCUMENT IN PART OR IN WHOLE OR THEREON OF THE ITEMS SHOWN MAY BE MADE WITHOUT THE COPYRIGHT OWNERS WRITTEN PERMISSION		SCALE 0.015	SHEET 1 OF 1
UNLESS OTHERWISE SPECIFIED ALL DIMENSIONS ARE IN mm. TOLERANCES ARE: X +/- 1.0 X.X +/- 0.25 X.XX +/- 0.025 ANG +/- .5		TITLE	
DO NOT SCALE		PROJECT	MODEL NAME TRACK_SUPPORT
		ISSUE	

1

2

3

4